

INGROUND 1 STAINLESS LED recessed - luminaire



The stylishly modern and unassuming exterior of INGROUND 1 STAINLESS houses state-of-the-art LED technology and made using the highest quality materials and construction methods. Bringing the flexibility to outdoor application, this powerful lighting fixture is ideally suited to use in landscape and building illumination, and IP67 ensures safe operation in even the most demanding areas.



PRODUCT SPECIFICATIONS

- INPUT VOLTAGE: 12V DC (LOW VOLTAGE)
- EFFICIENCY: > 92 %
- POWER CONSUMPTION: 1 LED ... 1,5W (up to 120 lm)
- LIFETIME: > 70 000 hours
- THERMAL PROTECTION: yes
- LED DEVICE: OSRAM high power LEDs
- LED VARIANTS: 3000K, 4000K, 5700K and other according requirement
- WEIGHT: 0,3 kg
- OPERATING TEMPERATURE: range -20°C to +45°C
- ENVIRONMENT: for OUTDOOR use, IP67
- MATERIALS: housing-die-Stainless steel, cover-tempered glass and Stainless Steel ring
- CONTROL: no control protocol, only ON/OFF option

DIMENSIONAL DRAWINGS

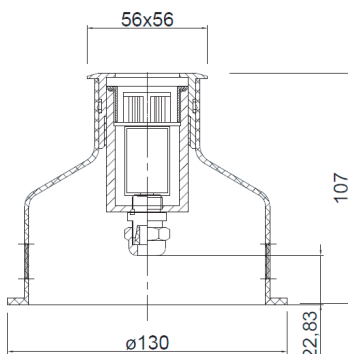

VARIANTS



INGROUND - ROUND



INGROUND - SQUARE

INGROUND 1 STAINLESS LED recessed - luminaire

PHOTOMETRICS

- Variants: SPOT, NARROW, MEDIUM

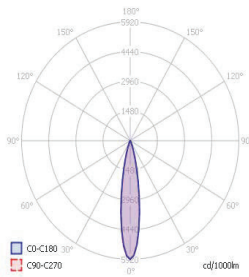
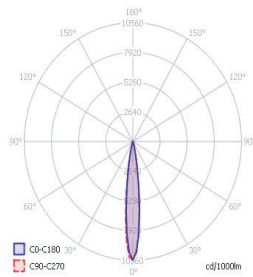
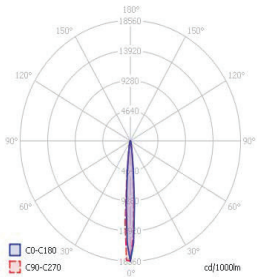

ACCESSORIES

- Constant Voltage power supply 230/12V ect.

CONNECTION

- Option 12V DC

