

## INGROUND PATH STAINLESS 19090 (ON/OFF, DALI, DMX)



The stylishly modern and unassuming exterior of INGROUND PATH. Stainless steel cover with four open windows.

OSRAM LED TECHNOLOGY INCLUDED and manufactured in Czech republic. Passive cooling of LED/COB with optimised heat sink geometry. No multiple shadows, energy-efficient LEDs with very good colour rendering; binning initial  $\leq 3$  MacAdam; available in the light colours 2700K, 3000K and 4000K, 5000K.min. 80 % of the luminous flux after 50000 hours; protection class IP 67; option control system - DALI or DMX dimmable.



### PRODUCT SPECIFICATIONS

- INPUT VOLTAGE: 100-240V 50Hz AC
- EFFICIENCY: > 92 %
- POWER CONSUMPTION: 4×1W LED...4,8 W (up to 96 lm)
- LIFETIME: > 70 000 hours
- THERMAL PROTECTION: yes
- LED DEVICE: OSRAM LED TECHNOLOGY
- LED VARIANTS: 2700K, 3000K, 4000K, 5000K and other according requirement
- WEIGHT: 0,69 kg
- OPERATING TEMPERATURE: range -20°C to +40°C
- ENVIRONMENT: for OUTDOOR use, IP67...>5Nm, 1000 kg
- MATERIALS: housing-die-cast Aluminium, cover- stainless steel-four windows,PMMA difuzor
- CONTROL: ON/OFF, DALI, DMX

### DIMENSIONAL DRAWINGS

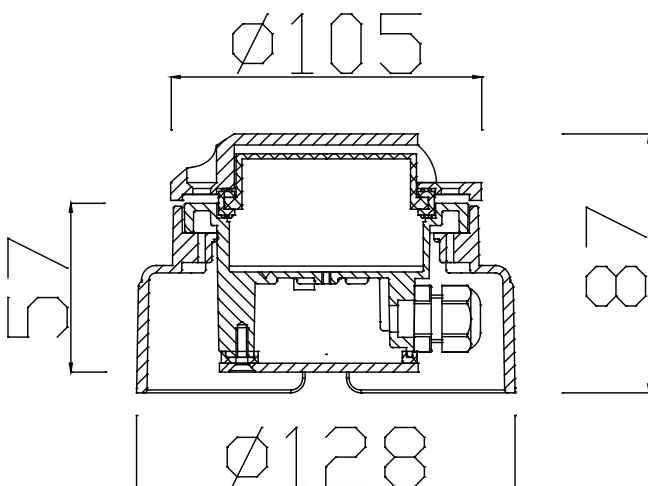

## INGROUND PATH STAINLESS 19090 (ON/OFF, DALI, DMX)

### PHOTOMETRICS

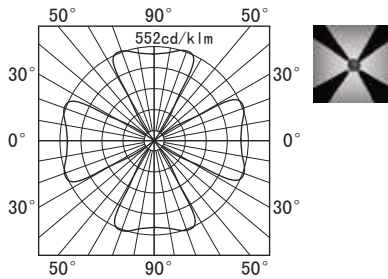

### ACCESSORIES

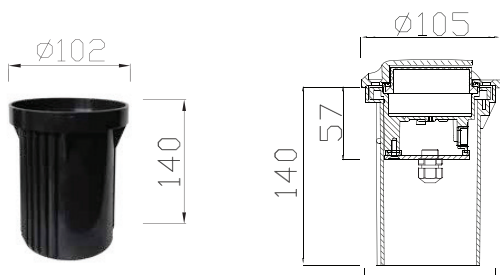

### CONNECTION

SERIAL CONNECTION MUST BE DONE BY CERTIFIED ELECTRICIAN