

INGROUND LINEAR

ON/OFF or DALI

Length = 650/950/1250



INSTRUCTIONS MANUAL

PRECILUM[®]
SPECIAL LED LIGHTING SOLUTIONS

TABLE OF CONTENTS

1. INTRODUCTION	2
2. SAFETY AND OPERATION	4
3. INSTALLATION	5
4. CONNECTION DIAGRAMS	10
5. CARE AND MAINTENANCE	12
6. TECHNICAL SPECIFICATION	13
7. WARRANTY STATEMENT	14

LED



**Electrostatic Sensitive Device
(ESD)**

**FOR YOUR OWN SAFETY PLEASE READ THIS INSTRUCTION
MANUAL CAREFULLY BEFORE BEGINNING SETUP AND
INSTALLATION.**

1. INTRODUCTION

1.1 About the product

The modules generate WHITE light by means of the high power LEDs. The products were designed for exterior use and they are ideal for locations where effect lighting with long lifetime is required. The INGROUND LINEAR range combines OSRAM LED technology with a balanced design to create truly specific lighting systems including TRIDONIC drivers. Using precision manufacturing techniques the INGROUND LINEAR provides professional solutions for your lighting requirements. Also, it has a passive cooling for optimum thermal management. It made using highest quality materials and construction methods, bringing the flexibility to outdoor application. This powerful lighting fixture is ideally suited to use in landscape and building illumination and IP67 ensures safe operation in even the most demanding areas.

The product is not suitable for environments with elevated salt content (seaside environments, winter salting, etc.). Products from the "Marine" range or stainless steel products are designed for this environment.

1. INTRODUCTION

1.2 Dimensions

Length = 650 mm

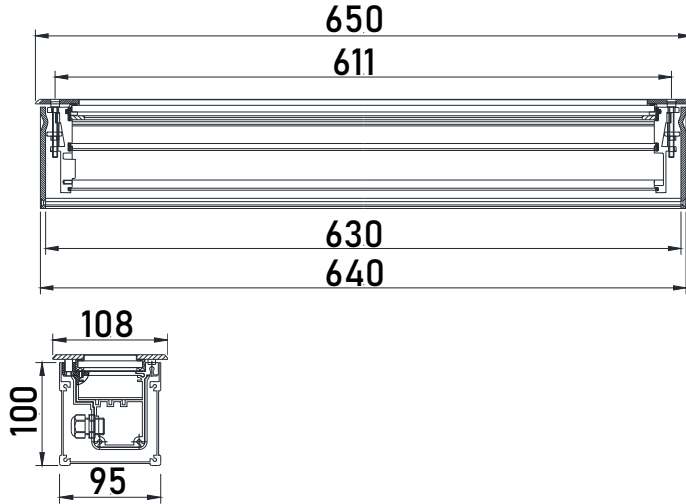

Length = 950 mm

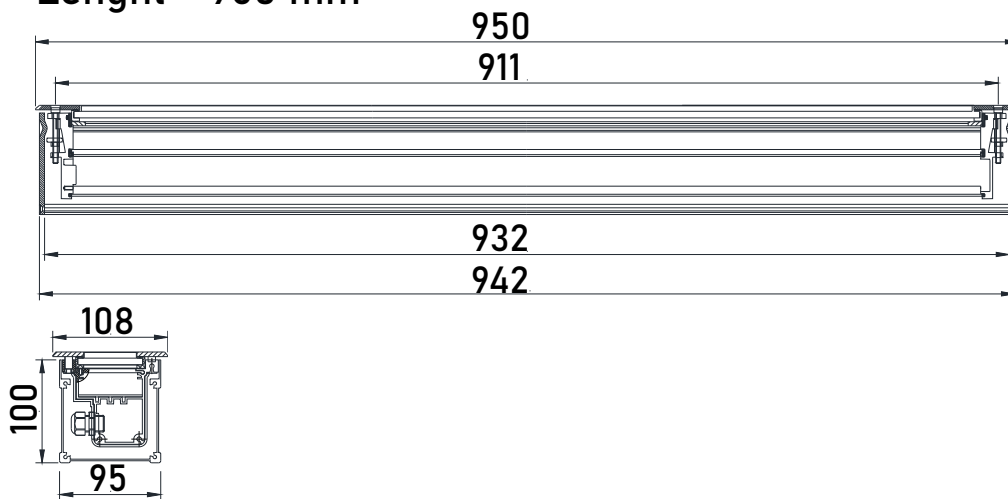

Length = 1250 mm

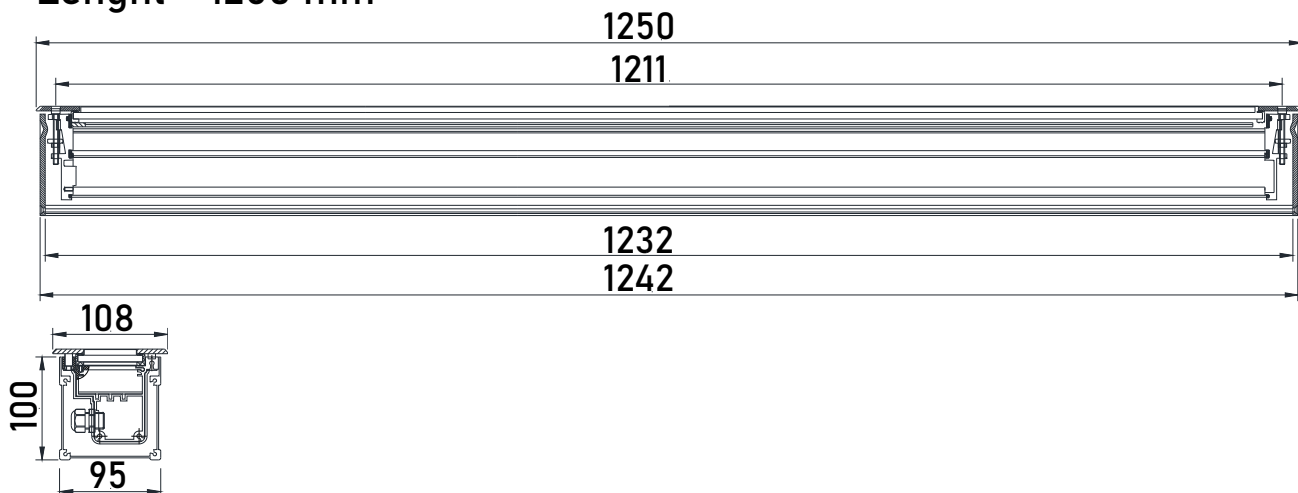

2. SAFETY AND OPERATION

CAUTION - DANGEROUS VOLTAGE CONSTITUTING A RISK OF ELECTRIC SHOCK IS PRESENT WITHIN THIS UNIT!

CAUTION - THE POWER SUPPLY MUST BE UNPLUG FROM THE MAINS POWER BEFORE CONNECTING ANY CABLES TO AVOID DAMAGING THE PRODUCT!

CAUTION – FOR YOUR OWN SAFETY AVOID LOOKING DIRECTLY INTO THE LED LIGHT SOURCE!

ANY PERSONS WHO INSTALLING THIS PRODUCT MUST BE QUALIFIED FOR THE HANDLING OF ELECTRICAL EQUIPMENT AND INSTALLATION MUST BE PERFORMED WITH LOCAL STANDARTS AND REGULATIONS!

- Consider the respective national norms during the installation!
- Install this luminaire with properly prepared drainage under this fixture,see installation page
- **Drainage assure that fixture will not be sink in water. IP67 !!! (its not IP68)**
- Do not install the fixture near the naked flames.
- Do not install the fixture in dirty or dusty location.
- Do not looking directly into the LED light beam at close range.
- Turn off the power prior to light fixture installation!
- The light fixture may be installed only by a qualified person!
- The light fixture must be wired according to respective electrical standards.
- The manufacturer shall not be liable for any modifications of the product of incorrect installation of the product.
- Never install the luminaire on rain, fog or high humidity.

3. INSTALLATION

3.1 Hardware installation

Fixation of aluminium sleeve

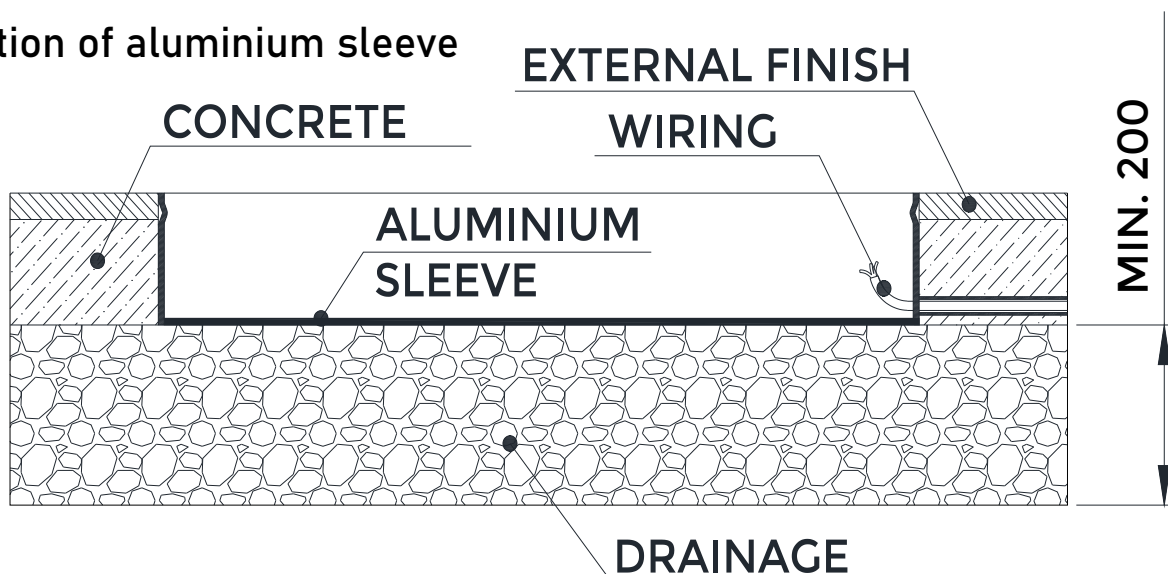

- Prepare always 20-30 cm of drainage gravel and check that it works: fill the tube of water and check that it completely disappear within 30 min. If it doesn't work study a further drainage system.
- Aluminum sleeve must be installed on drainage layers, surrounding concrete layers and leveled with external finish.

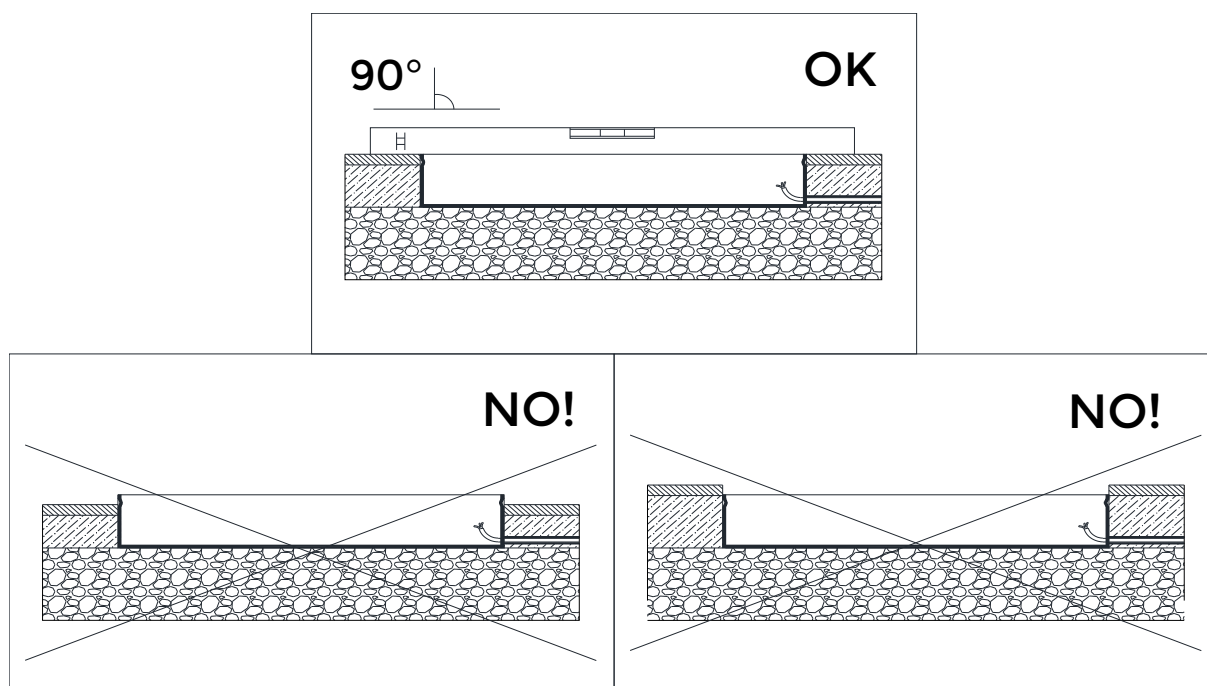

3. INSTALLATION

Fixation of fixture

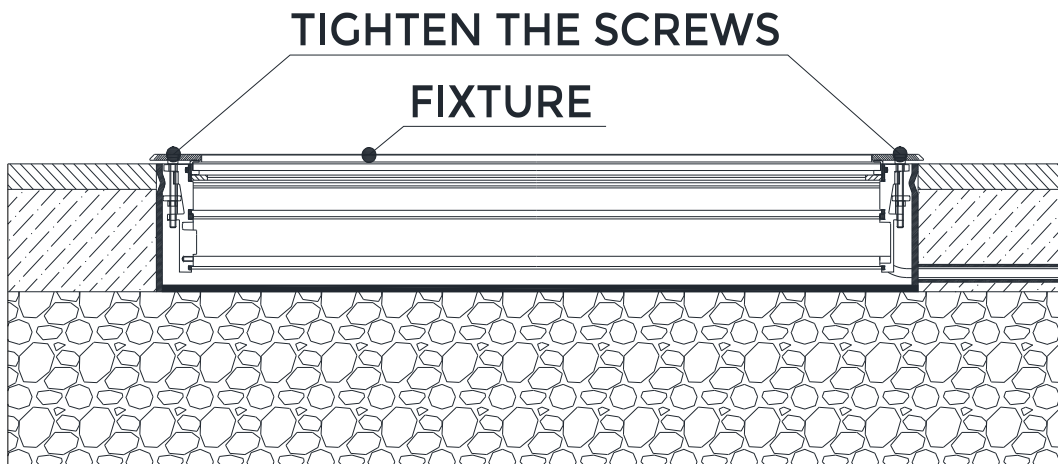

- Insert the fixture into the prepared aluminum sleeve.
- By tightening the two screws located on the edge of the fixture, we fixed the fixture.
- Never cover visible parts of the fittings. Any part not protected by the recessing box, must not be in direct contact with the ground or in contact with aggressive chemical elements.

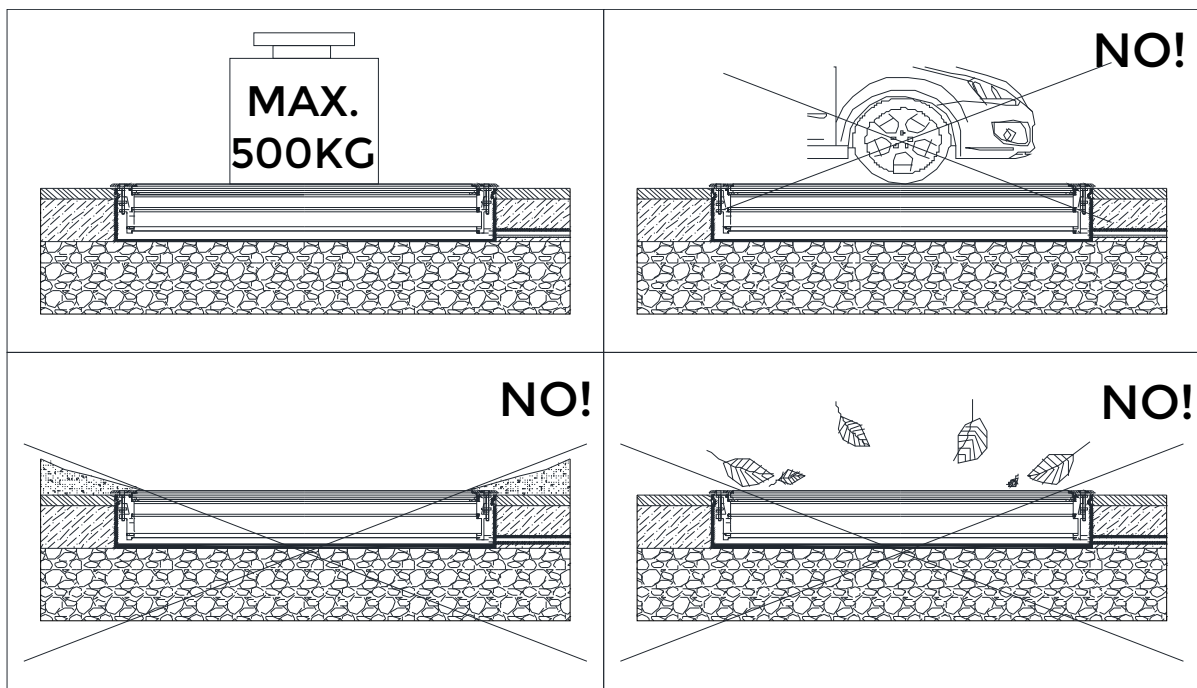

3. INSTALLATION

3.2 Connection

3.2.1 Wiring - ON/OFF option

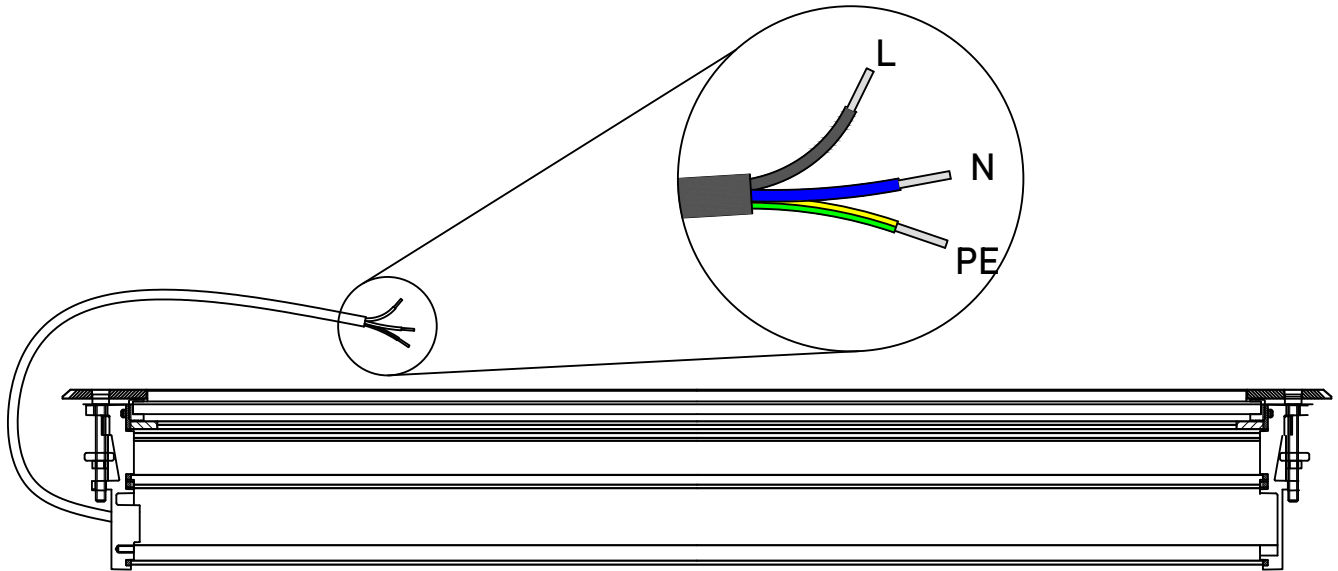

Wire L (Live) – black/brown

Wire N (Neutral) – blue

Wire PE (Earth) – yellow/green

3. INSTALLATION

3.2 Connection

3.2.2 Wiring - DALI option

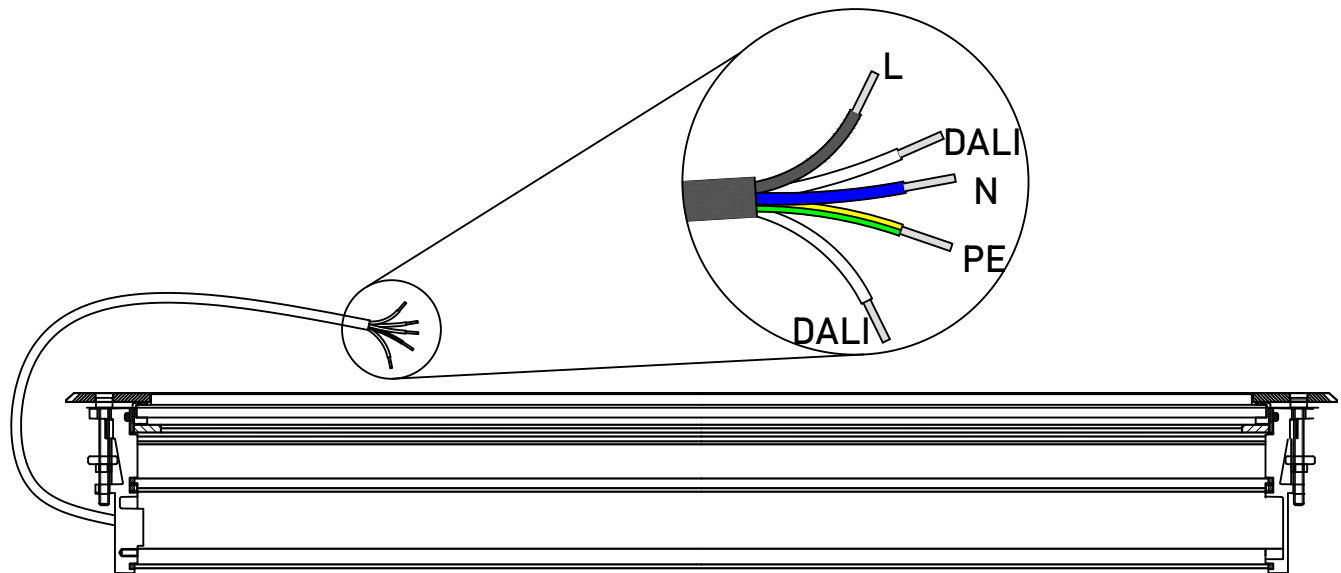

Wire L (Live) – black/brown

Wire N (Neutral) – blue

Wire PE (Earth) – yellow/green

Wire DA1 (Dali) – white

Wire DA2 (Dali) – white

3. INSTALLATION

3.3 IP BOX connection

PRECILUM requirement:

Use a SCAME IP box or similar (not included).



Must be made a waterproof connection of at least IP68. We strongly recommend to use special two components silicone GEL for sealing junction boxes containing electrical connections. **If the IP rating of the connection is not observed, the complaint will not be accepted!**

For example:

<https://www.etelec.com/prodotto/mpgel/>

Video tutorial:

<https://www.youtube.com/watch?v=tj6ksKdzuE0>



4. CONNECTION DIAGRAMS

4.1 ON/OFF option

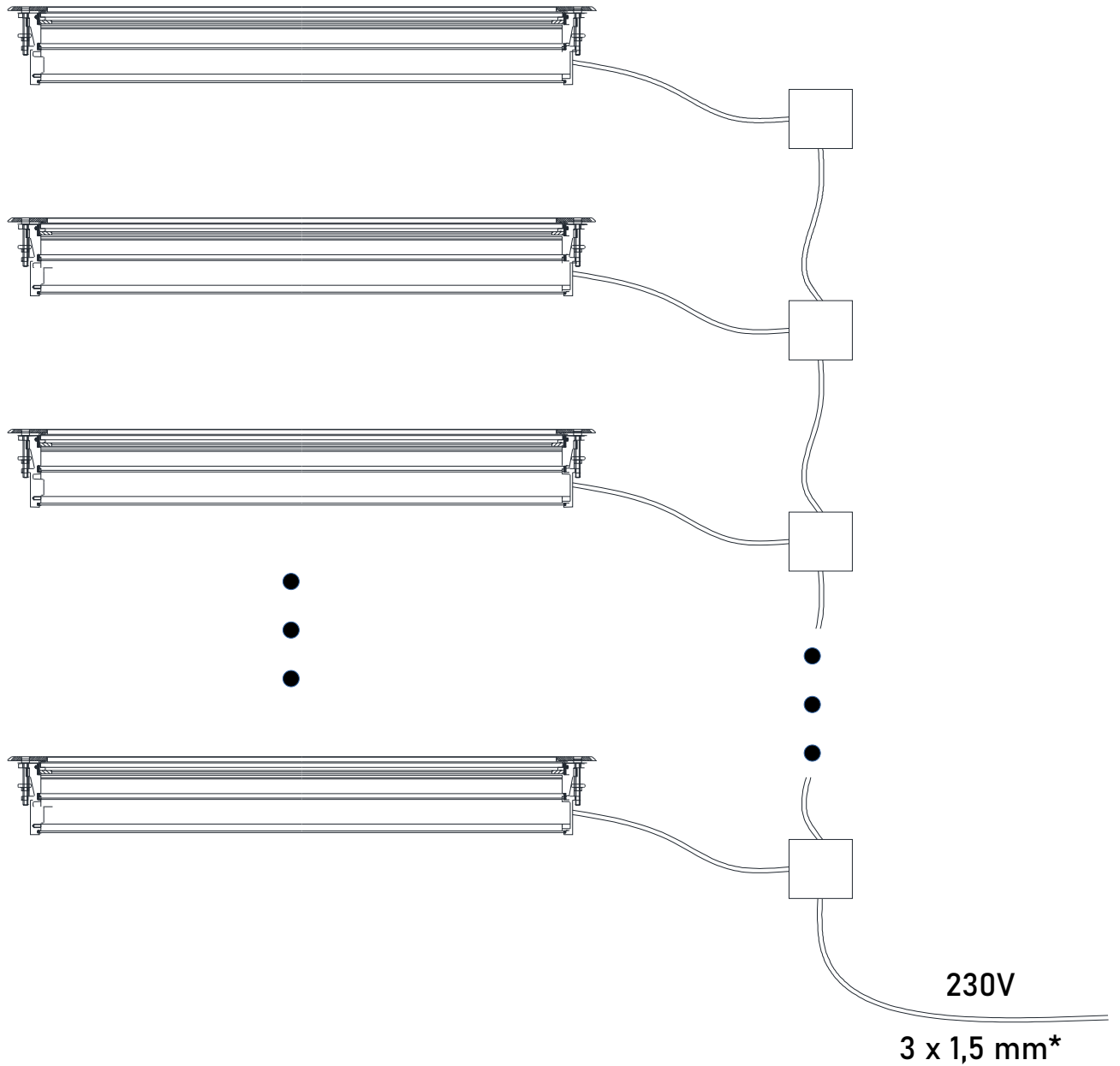

Description:

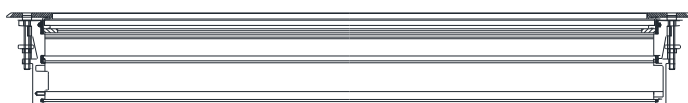

- Luminaire



- Junction box

*Must be specified by the electrical designer.

4. CONNECTION DIAGRAMS

4.1 DALI option

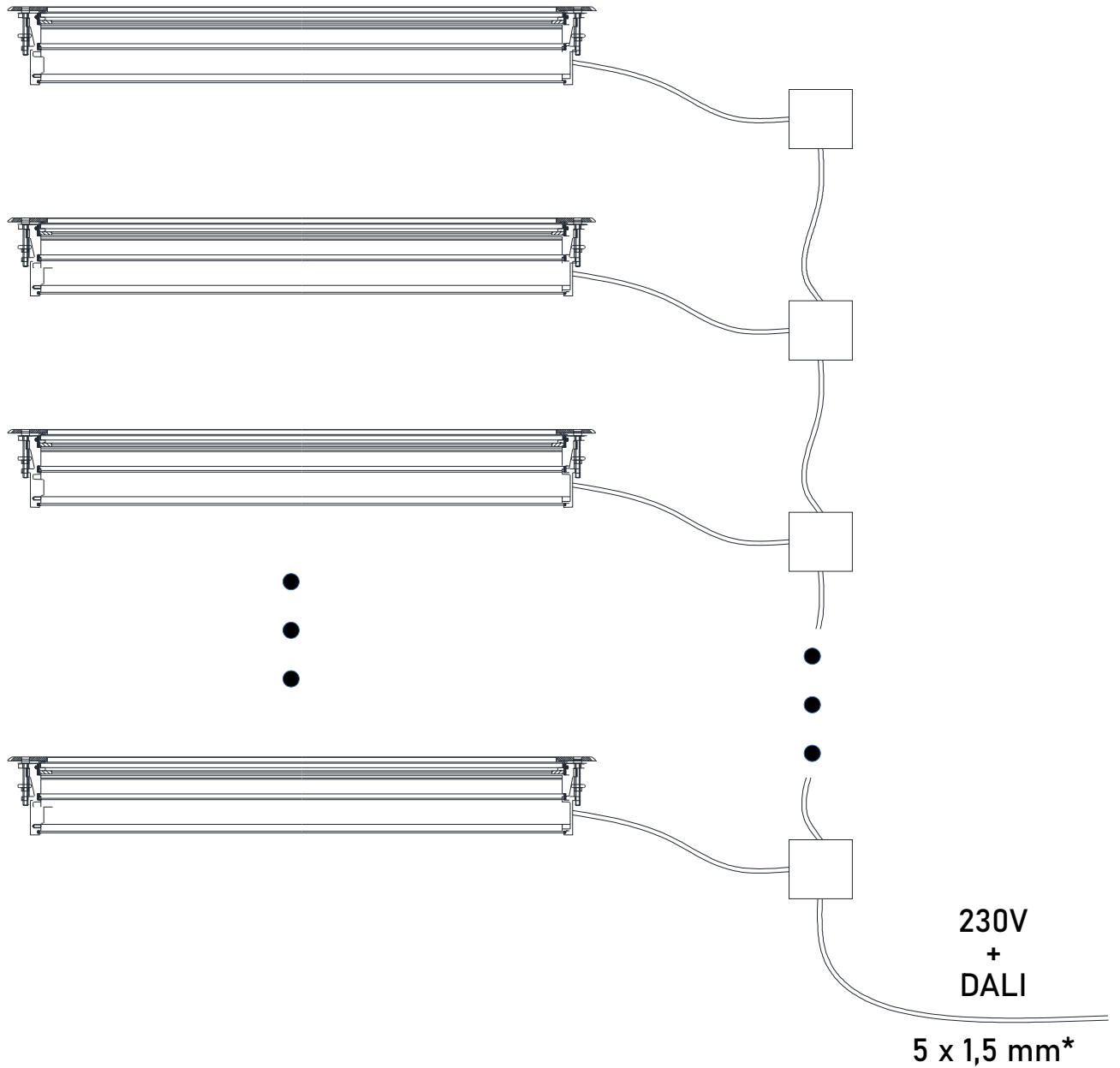

*Must be specified by the electrical designer.

Description:

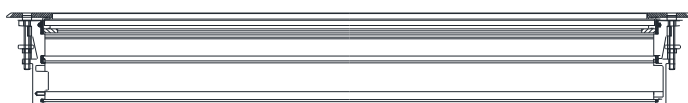

- Luminaire



- Junction box

5. CARE AND MAINTENANCE

PRECILUM™ PRODUCTS ARE OF SUPERIOR DESIGN AND QUALITY AND SHOULD BE TREATED WITH CARE. THE RECOMMENDATIONS BELOW WILL HELP FULFILL GAIN GOOD USE AND LONGEVITY FROM THE PRODUCTS.

Clean the front transparent cover at least every 6 months. Use a moist, lint-free cloth. Never use alcohol or solvents.

A scheduled maintenance programme must be carried out on the installation and the fittings regardless of their IP rating or application – these must include the following operations:

- Clean the fittings from dirt that may be deposited on the protection grills and in the heads of the screws by following the installation instructions attached to each fitting.
- Check that the screws are not loose on the various components of the luminaire (glass frame, cable entry , ...).
- Check each cable gland, and cable for damage and that the cable gland has not come loose.
- For each Isolation Class 1 fitting check that the earth cable has not come loose. The clip must not show signs of oxidation, damage or become loose.
- For class 2 fittings check any eventual plastic / isolating covering in order to verify any damage.
- Check that all the seals are in good condition and that they are not dry, damaged or split.
- Check the glass or plastic screen for damage and replace if required.
- Check for water inside the luminaire's housing and its recessing box.

The internal components such as the ballasts, transformers, washers and screws must not show clear signs of oxidation or rust.

Clear traces of rust and oxidation will indicate the presence of water inside the luminaire.

In case of damage the components must be replaced by original components and spare parts before using the fitting.

We also recommend to check the fitting each time the lamp is replaced or at least once a year or within the prescribed maintenance schedule period depending on the type of installation.

6. TECHNICAL SPECIFICATION

Mounting:	Ground recessed
Optical system:	Spot, Narrow, Medium, Wide, Flood, Oval, Assym.
LED device:	High power OSRAM LEDs
LED colour:	2700K, 3000K, 4000K, 5700K
Lumen output:	See datasheet
Input voltage:	230V 50Hz AC
Driver type:	Electronic control gear TRIDONIC
Max. power consumption:	INGROUND LINEAR 650 18W (current 350mA) / 27W (current 500mA) INGROUND LINEAR 950 27W (current 350mA) / 40W (current 500mA) INGROUND LINEAR 1250 36W (current 350mA) / 54W (current 500mA)
Service lifetime:	70 000 hrs./L70 @25°C
Operation ambient temp:	-20°C/+40°C
Materials:	Housing: die cast aluminium Cover: clear hardened glass+stainless steel cover
Dimensions:	See dimensional drawing
Environment:	IP67
Weight:	INGROUND LINEAR 650: 5,9 kg INGROUND LINEAR 950: 8,6 kg INGROUND LINEAR 1250: 10,5 kg
Accessories:	See website

7. WARRANTY STATEMENT

Precilum provides a product warranty for a period of five (5) years from date of purchase.

The product is not suitable for environments with elevated salt content (seaside environments, winter salting, etc.). Products from the "Marine" range or stainless steel products are designed for this environment. Failure to comply with these conditions will not be accepted as a warranty complaint.

Please refer www.precilum.com for all warranty terms and conditions.



Please check for latest updates and changes on the Precilum website.

©2021 PRECILUM s.r.o ALL RIGHT RESERVED. All specifications subject to change without notice.

WWW.PRECILUM.COM