

# INGROUND 15 INGROUND 24 WHITE

ON/OFF or DALI



Round



Square

**INSTRUCTIONS MANUAL**

**PRECILUM**<sup>®</sup>  
SPECIAL LED LIGHTING SOLUTIONS

# TABLE OF CONTENTS

1. INTRODUCTION	2
2. SAFETY AND OPERATION	4
3. INSTALLATION	5
4. CONNECTION DIAGRAMS	13
5. CARE AND MAINTENANCE	15
6. TECHNICAL SPECIFICATION	16
7. WARRANTY STATEMENT	17

LED



**Electrostatic Sensitive Device  
(ESD)**

**FOR YOUR OWN SAFETY PLEASE READ THIS INSTRUCTION  
MANUAL CAREFULLY BEFORE BEGINNING SETUP AND  
INSTALLATION.**

# 1. INTRODUCTION

---

## 1.1 About the product

The PRECILUM Inground range brings the INGROUND to the outdoor world of exterior lighting. With IP67 rating and drive over capability these Inground fixtures are capable of meeting most exterior applications.

The refined thermal management system incorporates a sleek and robust heat-sink directly into the fixture to ensure maximum heat transfer and long life-time.

**The product is not suitable for environments with elevated salt content (seaside environments, winter salting, etc.).** Products from the "Marine" range or stainless steel products are designed for this environment.

# 1. INTRODUCTION

## 1.2 Dimensions

### Inground 15

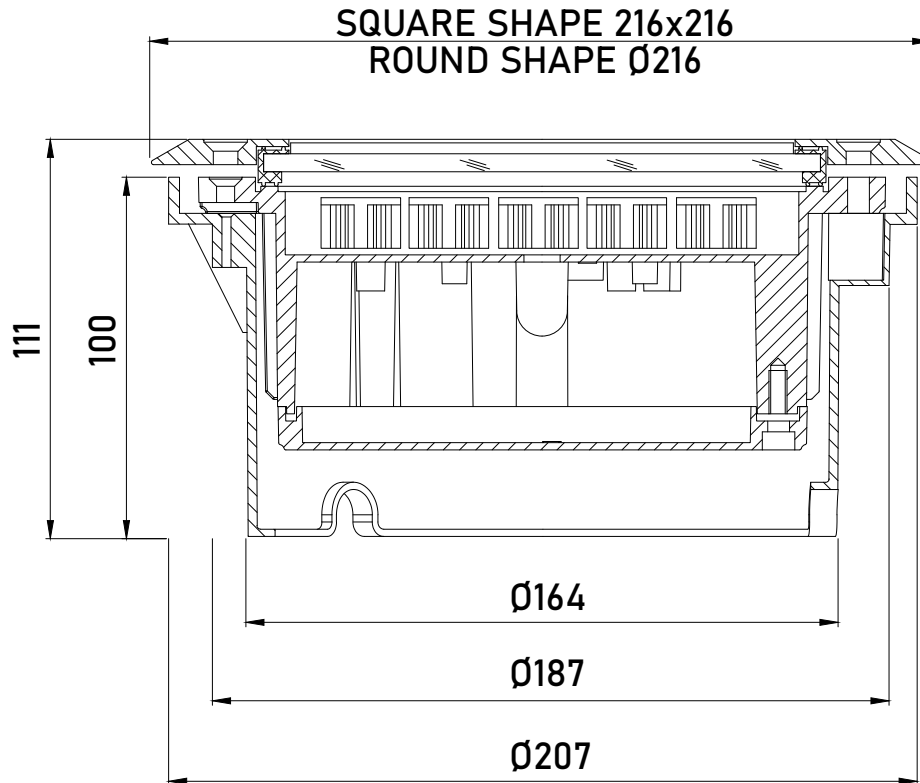

### Inground 24

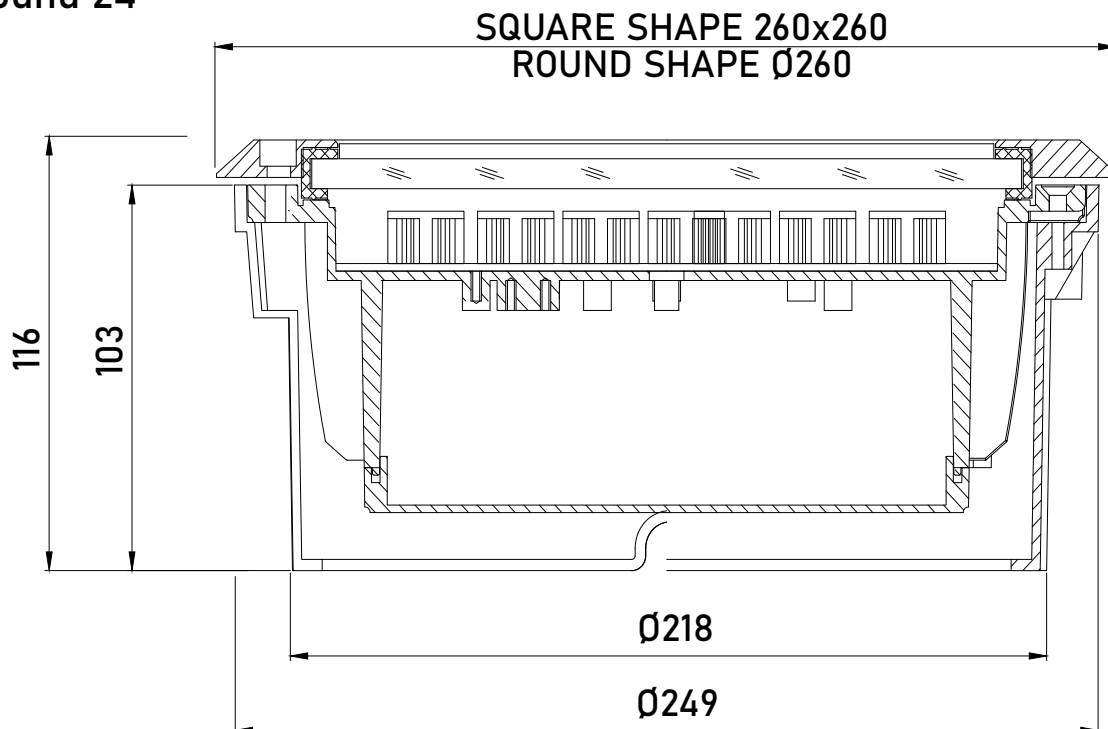

## 2. SAFETY AND OPERATION

**CAUTION - DANGEROUS VOLTAGE CONSTITUTING A RISK OF ELECTRIC SHOCK IS PRESENT WITHIN THIS UNIT!**

**CAUTION - THE POWER SUPPLY MUST BE UNPLUG FROM THE MAINS POWER BEFORE CONNECTING ANY CABLES TO AVOID DAMAGING THE PRODUCT!**

**CAUTION – FOR YOUR OWN SAFETY AVOID LOOKING DIRECTLY INTO THE LED LIGHT SOURCE!**

**ANY PERSONS WHO INSTALLING THIS PRODUCT MUST BE QUALIFIED FOR THE HANDLING OF ELECTRICAL EQUIPMENT AND INSTALLATION MUST BE PERFORMED WITH LOCAL STANDARTS AND REGULATIONS!**

- Consider the respective national norms during the installation!
- Install this luminaire with properly prepared drainage under this fixture, see installation page
- **Drainage assure that fixture will not be sink in water. IP67 !!! (its not IP68)**
- Do not install the fixture near the naked flames.
- Do not install the fixture in dirty or dusty location.
- Do not looking directly into the LED light beam at close range.
- Turn off the power prior to light fixture installation!
- The light fixture may be installed only by a qualified person!
- The light fixture must be wired according to respective electrical standards.
- The manufacturer shall not be liable for any modifications of the product of incorrect installation of the product.
- Never install the luminaire on rain, fog or high humidity.

## 3. INSTALLATION

### 3.1 Hardware installation

#### 3.1.1 Fixation of plastic sleeve

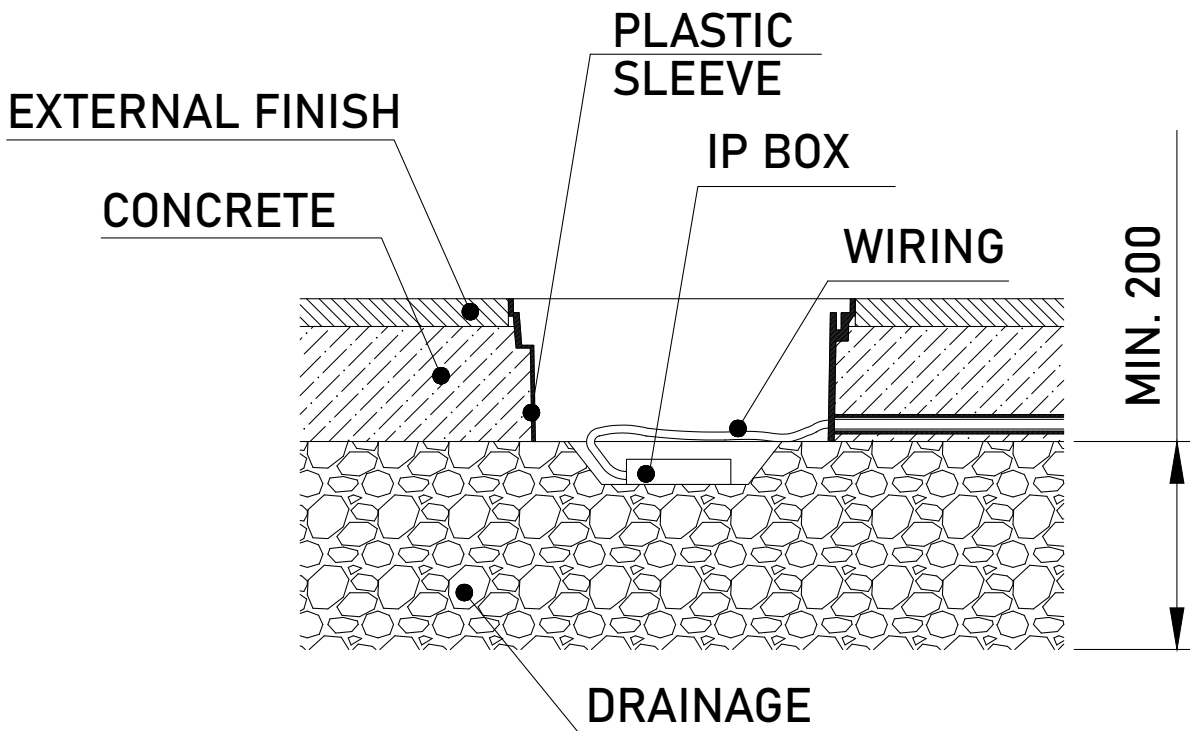

- Prepare always 20-30 cm of drainage gravel and check that it works: fill the tube of water and check that it completely disappear within 30 min. If it doesn't work study a further drainage system.
- Aluminum sleeve must be installed on drainage layers, surrounding concrete layers and leveled with external finish.

### 3. INSTALLATION

Fig. 1

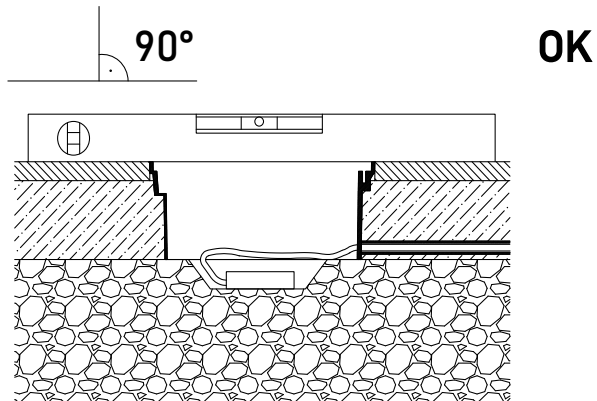

Fig. 1

- Install the plastic sleeve into the floor according to Fig. 1.
- The edges of the plastic sleeve must be flush with the surrounding floor.

Fig. 2

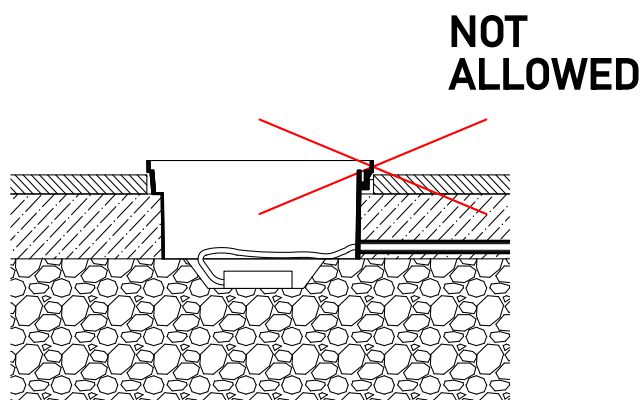

Fig. 2

- Edges of the plastic sleeve must not be installed above the surrounding floor.

Fig. 3

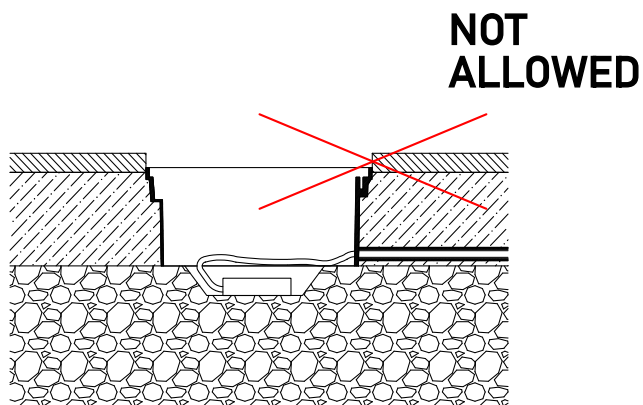

Fig. 3

- Edges of the plastic sleeve must not be installed under the surrounding floor.

## 3. INSTALLATION

### 3.1.2 Fixation of fixture

Fig. 4

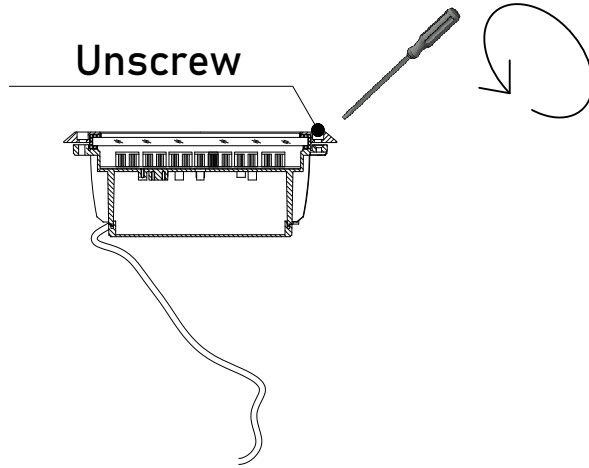

Fig. 4

- Remove the screws that secure the stainless steel face ring.

Fig. 5

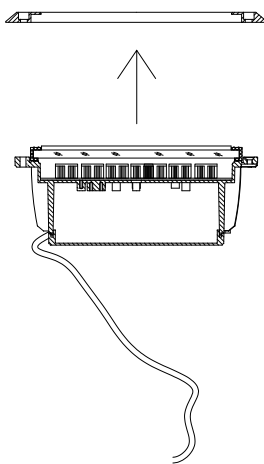

Fig. 5

- Remove the stainless steel face ring.
- **Do not remove tempered glass!!!**

Fig. 6

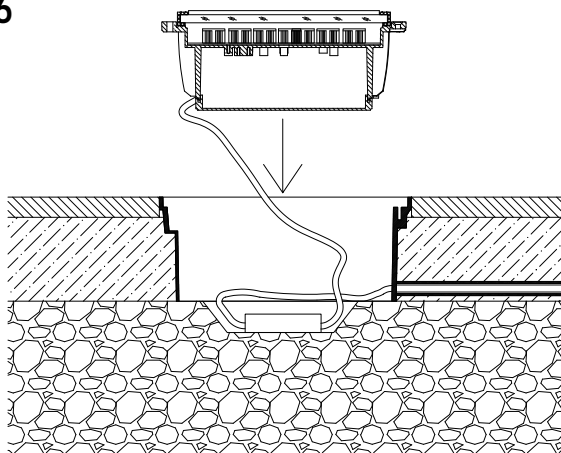

Fig. 6

- Connect the cable coming out of the luminaire with the supply cable in the **IP junction box** (more about IP connection in **3.3 IP BOX connection**).
- Put the luminaire into the plastic sleeve.



### 3. INSTALLATION

Fig. 7

Tighten the screws

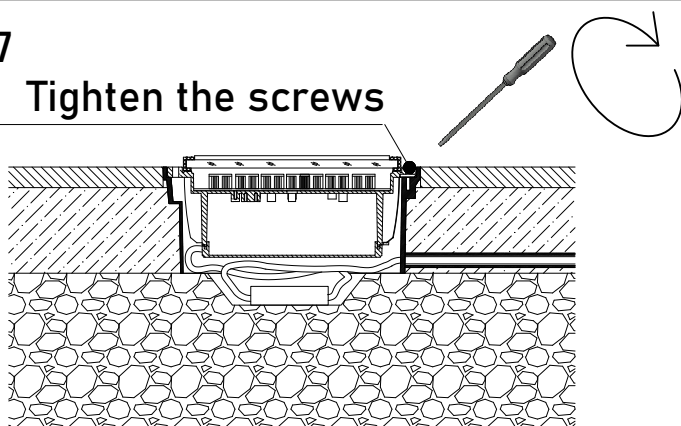

Fig. 7

- Fasten the luminaire to the plastic sleeve with the enclosed screws.

Fig. 8

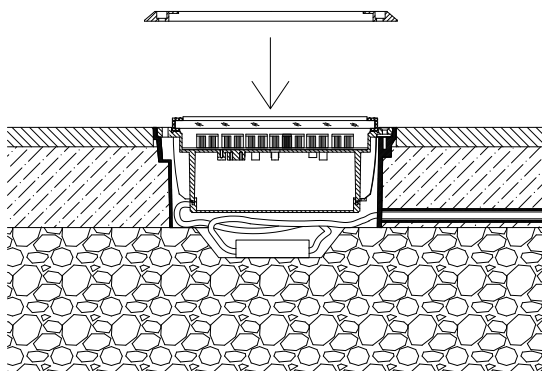

Fig. 8

- Put on the stainless steel front ring which you removed in step 5 (Fig.5).

Fig. 9

Tighten the screws

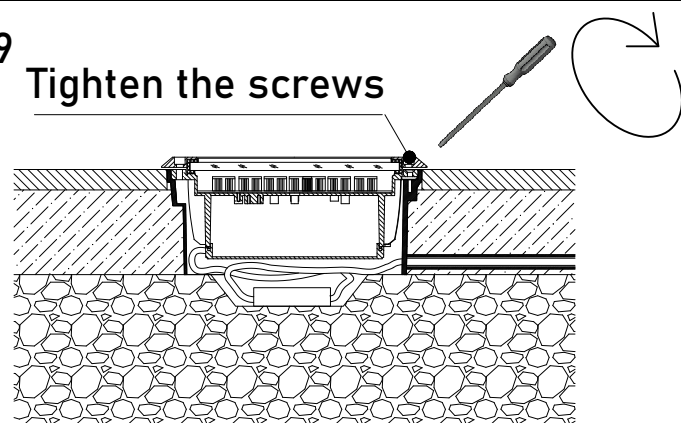
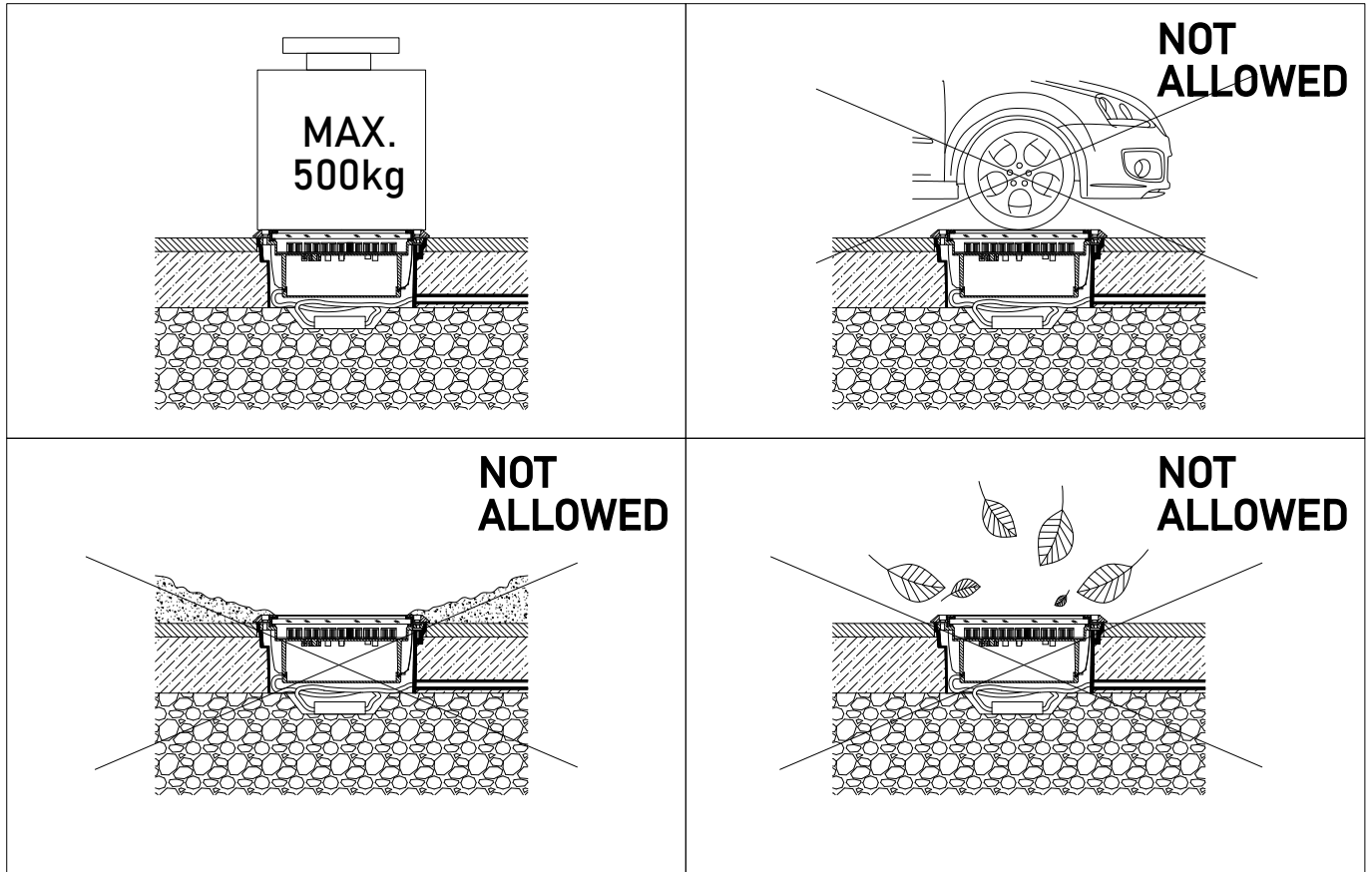

Fig. 9

- Put on and tighten the screws which you removed in step 4 (Fig.4).
- **Check if the screws are tight properly!**

### 3. INSTALLATION



# 3. INSTALLATION

## 3.2 Connection

### 3.2.1 Wiring - ON/OFF option

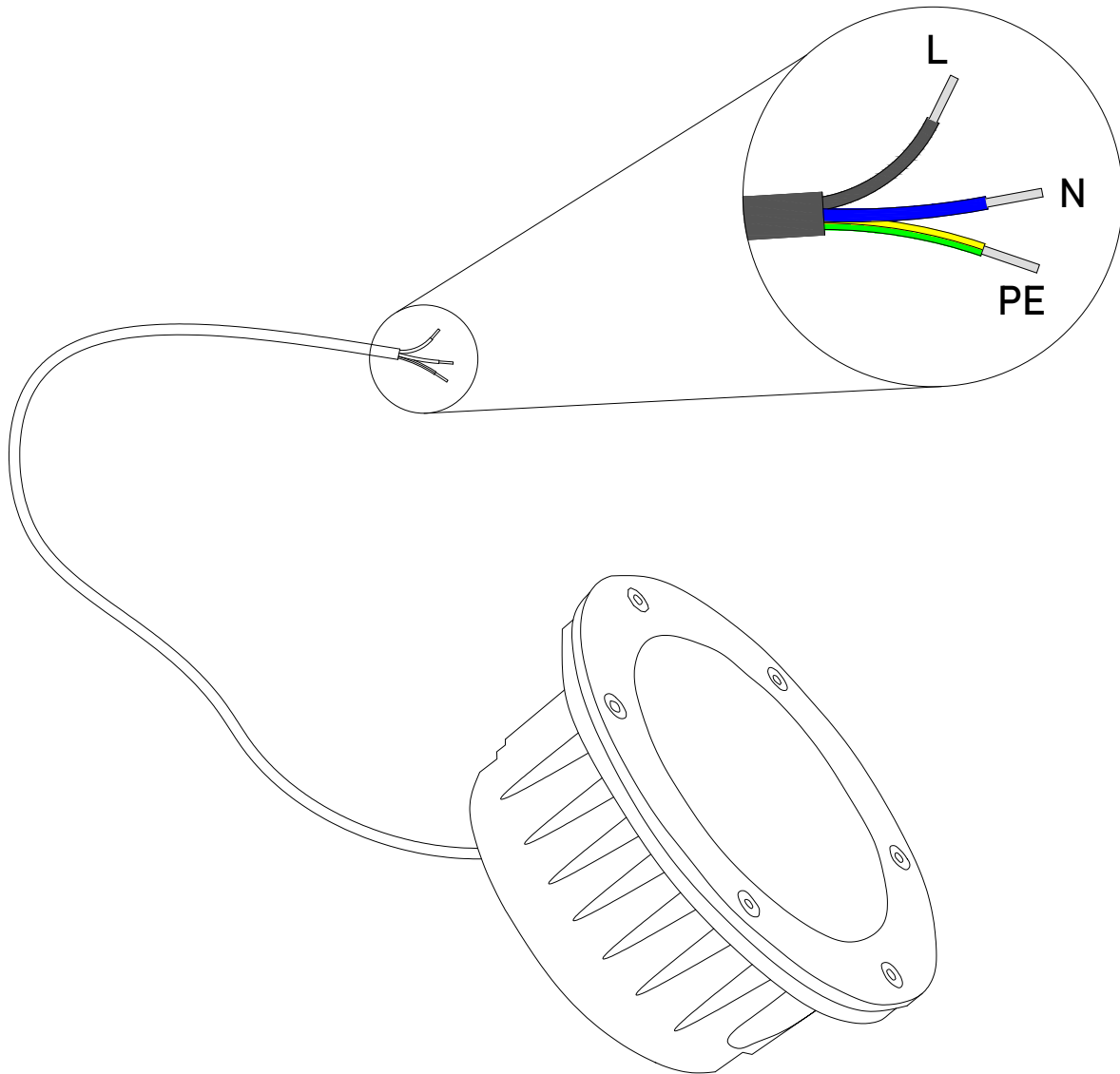

Wire L (Live) – black/brown

Wire N (Neutral) – blue

Wire PE (Earth) – yellow/green

## 3. INSTALLATION

### 3.2 Connection

#### 3.2.2 Wiring - DALI option

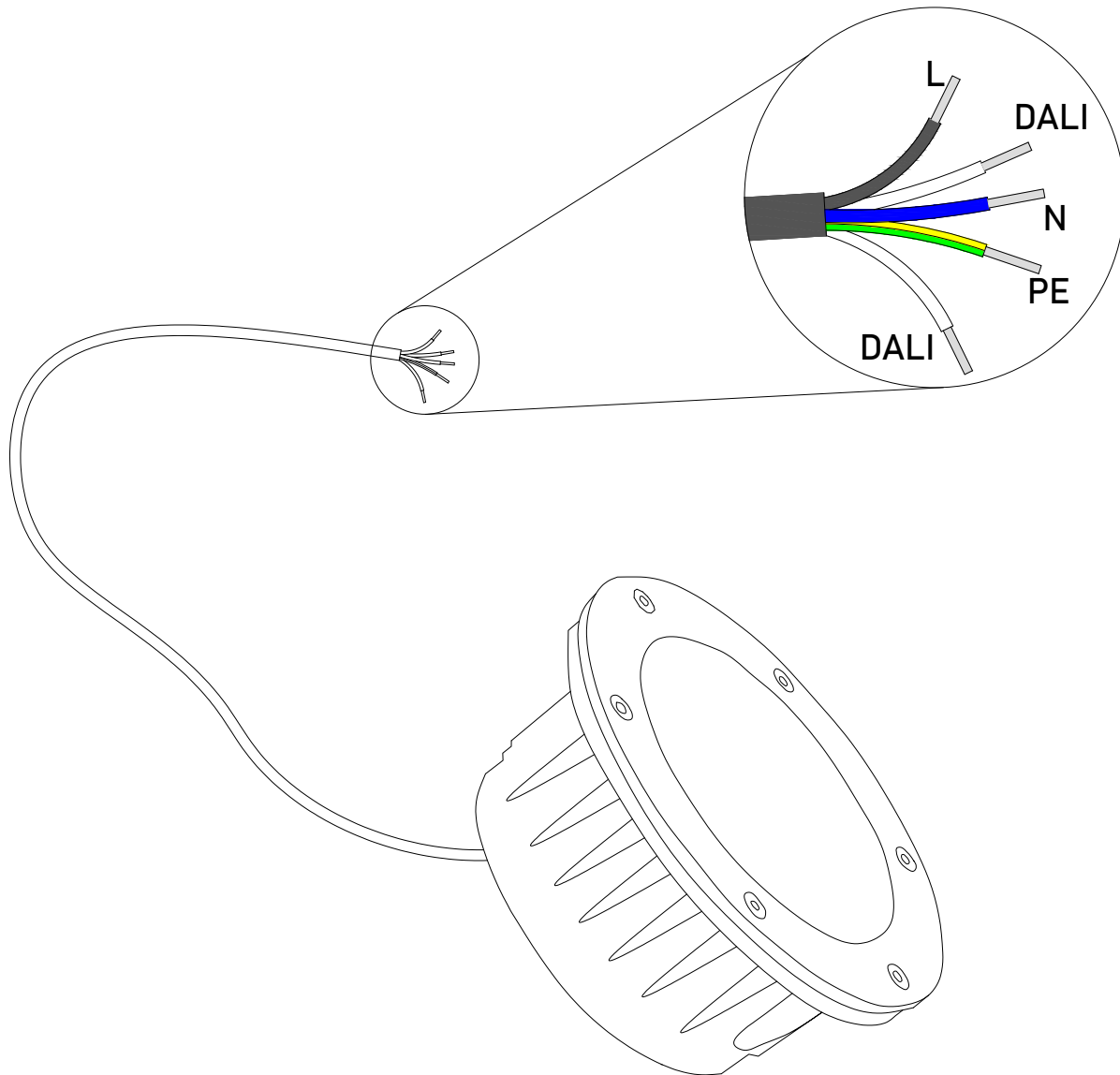

Wire L (Live) – black/brown

Wire N (Neutral) – blue

Wire PE (Earth) – yellow/green

Wire DA1 (Dali) – white

Wire DA2 (Dali) – white

## 3. INSTALLATION

### 3.3 IP BOX connection

PRECILUM requirement:

Use a SCAME IP box or similar (not included).



Must be made a waterproof connection of at least IP68. We strongly recommend to use special two components silicone GEL for sealing junction boxes containing electrical connections. **If the IP rating of the connection is not observed, the complaint will not be accepted!**

For example:

<https://www.etelec.com/prodotto/mpgel/>

Video tutorial:

<https://www.youtube.com/watch?v=tj6ksKdzuE0>



## 4. CONNECTION DIAGRAMS

### 4.1 ON/OFF option

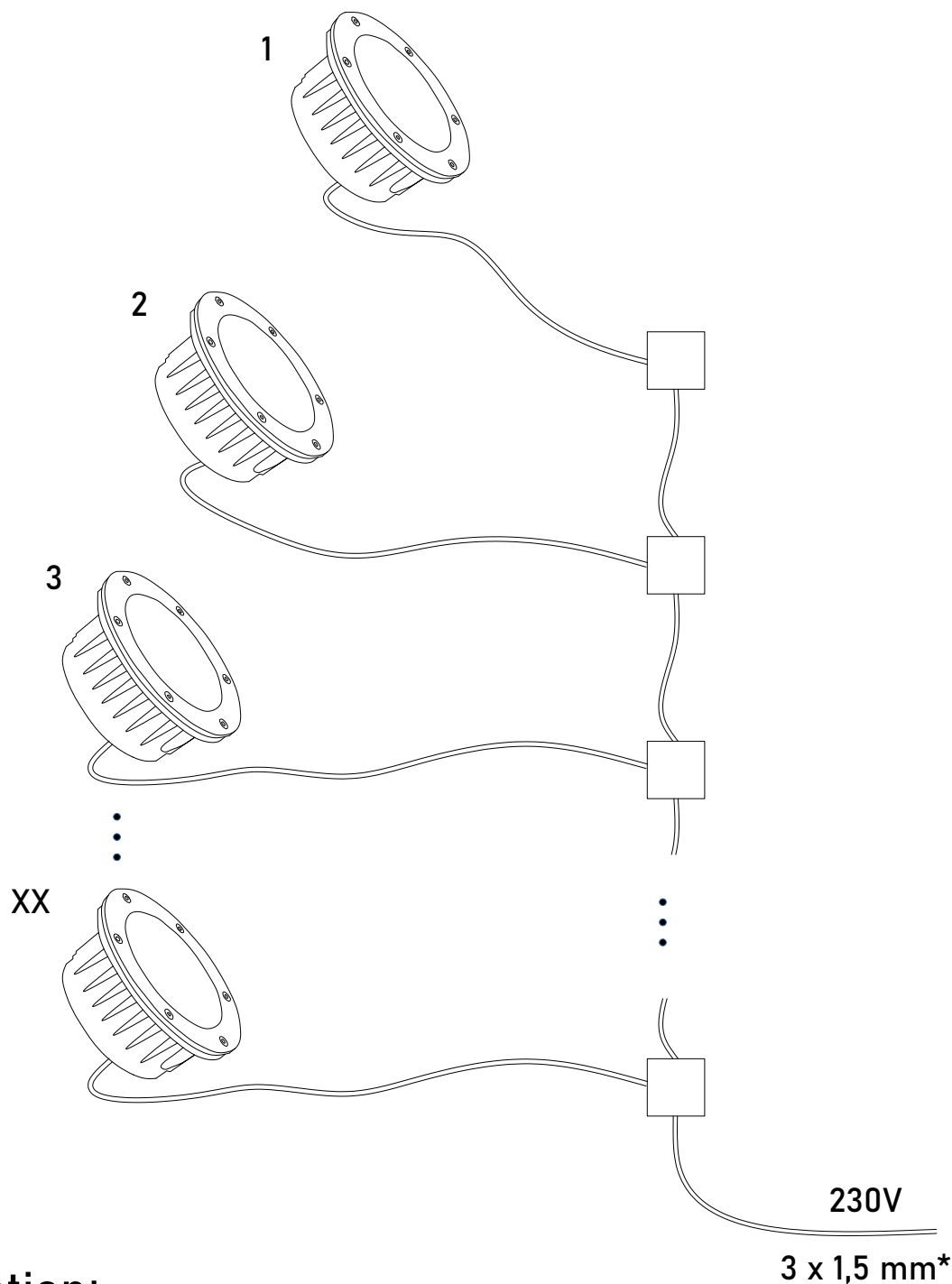

#### Description:

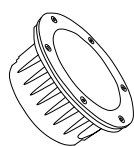

- Luminaire



- IP Junction box

\*Must be specified by the electrical designer.

## 4. CONNECTION DIAGRAMS

### 4.2 DALI option

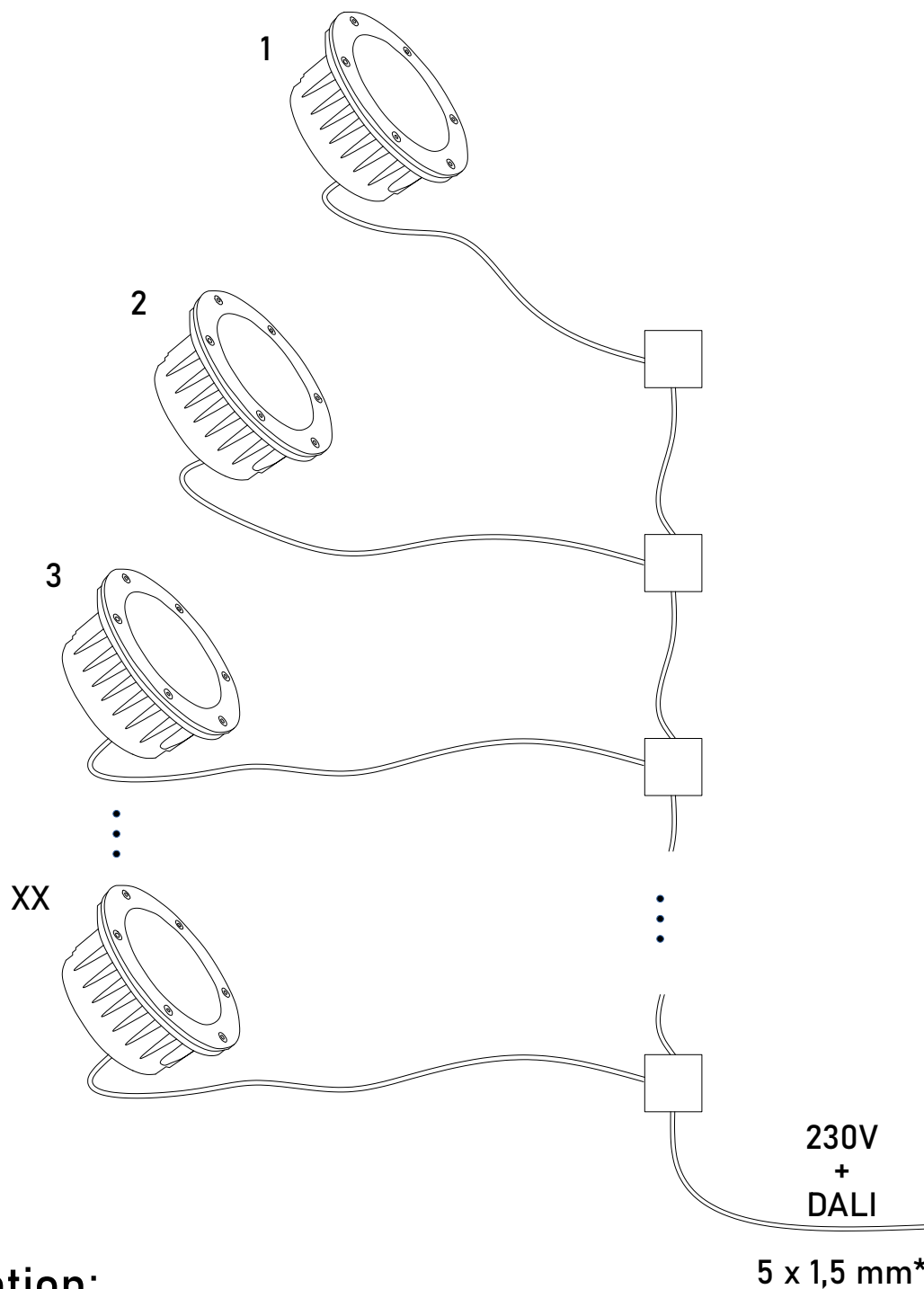

#### Description:

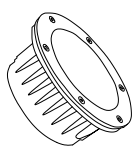

- Luminaire



- IP Junction box

\*Must be specified by the electrical designer.

## 5. CARE AND MAINTENANCE

**PRECILUM™ PRODUCTS ARE OF SUPERIOR DESIGN AND QUALITY AND SHOULD BE TREATED WITH CARE. THE RECOMMENDATIONS BELOW WILL HELP FULFILL GAIN GOOD USE AND LONGEVITY FROM THE PRODUCTS.**

Clean the front transparent cover at least every 6 months. Use a moist, lint-free cloth. Never use alcohol or solvents.

A scheduled maintenance programme must be carried out on the installation and the fittings regardless of their IP rating or application – these must include the following operations:

- Clean the fittings from dirt that may be deposited on the protection grills and in the heads of the screws by following the installation instructions attached to each fitting.
- Check that the screws are not loose on the various components of the luminaire (glass frame, cable entry , ...).
- Check each cable gland, and cable for damage and that the cable gland has not come loose.
- For each Isolation Class 1 fitting check that the earth cable has not come loose. The clip must not show signs of oxidation, damage or become loose.
- For class 2 fittings check any eventual plastic / isolating covering in order to verify any damage.
- Check that all the seals are in good condition and that they are not dry, damaged or split.
- Check the glass or plastic screen for damage and replace if required.
- Check for water inside the luminaire's housing and its recessing box.

The internal components such as the ballasts, transformers, washers and screws must not show clear signs of oxidation or rust.

Clear traces of rust and oxidation will indicate the presence of water inside the luminaire.

In case of damage the components must be replaced by original components and spare parts before using the fitting.

We also recommend to check the fitting each time the lamp is replaced or at least once a year or within the prescribed maintenance schedule period depending on the type of installation.



## 6. TECHNICAL SPECIFICATION

Mounting:	Ground recessed
Optical system:	Spot, Narrow, Medium, Wide, Flood, Oval, Assym.
LED device:	High power OSRAM LEDs
LED colour:	3000K, 4000K, 5700K and other accor. req.
Lumen output:	See datasheet
Input voltage:	230V 50Hz AC or 48V DC
Driver type:	Electronic control gear TRIDONIC or OSRAM
Max. power consumption:	INGROUND 15 WHITE 15W (current 350mA) / 23W (current 500mA) INGROUND 24 WHITE 24W (current 350mA) / 36W (current 500mA)
Service lifetime:	70 000 hrs./L70 @25°C
Operation ambient temp:	-20°C/+40°C
Materials:	Housing: die cast aluminium Cover: clear hardened glass+ stain. steel face ring
Dimensions:	See dimensional drawing
Environment:	IP67
Weight:	INGROUND 15 WHITE: 2,8 kg INGROUND 24 WHITE: 4,9 kg
Accessories:	See website

## 7. WARRANTY STATEMENT

---

Precilum provides a product warranty for a period of five (5) years from date of purchase.

**The product is not suitable for environments with elevated salt content (seaside environments, winter salting, etc.). Products from the "Marine" range or stainless steel products are designed for this environment. Failure to comply with these conditions will not be accepted as a warranty complaint.**

Please refer [www.precilum.com](http://www.precilum.com) for all warranty terms and conditions.





**Please check for latest updates and changes on the Precilum website.**

**©2021 PRECILUM s.r.o ALL RIGHT RESERVED. All specifications subject to change without notice.**

**WWW.PRECILUM.COM**